

FRL FPR-3/4"f

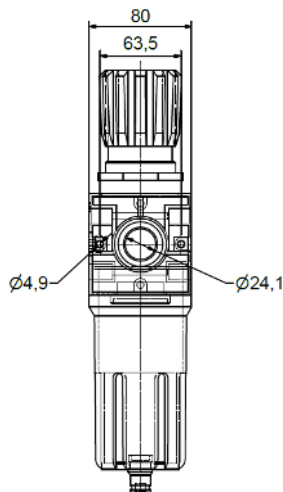

- Combines the technical benefits of the pressure reducer and the water separator with filter in one compact unit
- Pressure regulator with piston for high operational reliability
- Assembly independent of flow direction thanks to double-sided connection option for pressure gauge

- Working pressure range : 0-12 Bar
- Entry pressure: 0-18 bar
- Filter element: 20 µm

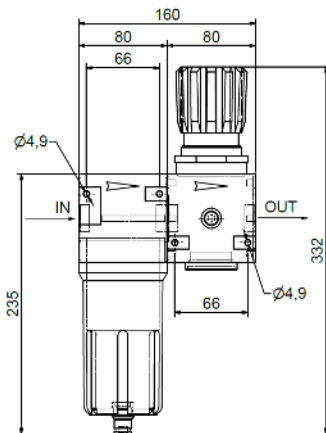

Specifications

Inlet Connection 3/4" Female BSP thread

Outlet Connection 3/4" Female BSP thread

Manometer Connection 3/4" Female BSP thread

Flow rate 3.600 l/min

Condensate tank volume 170 ml

Dimension 160x80x332

Ordering Information

Ordering Information	Weight KG
----------------------	-----------

2813 9200 17	1,704
--------------	-------