



MOBILAIR® M 82

Portable Compressors

With the world-renowned SIGMA PROFILE®

Flow rate 5.5 to 8.4 m³/min (195 – 295 cfm)

MOBILAIR® M 82

The powerful combination of a highly efficient KAESER SIGMA PROFILE rotary screw airend and an energy-saving engine, certified in accordance with EU Directive 2016/1628, Stage V, provides impressive fuel efficiency and super-clean performance. Together with other innovative features, this compact powerhouse is yet another dependable and efficient compressed air partner from KAESER.

Versatile

The MOBILAIR M 82 can be perfectly tailored to meet the specific needs of the individual application, thanks to a wide range of optional compressed air treatment components. Moreover, the option of a chassis with overrun brake, as well as a stationary version mounted on skids or machine feet, means that the M 82 is ideally suited to all working environments.

Safe and simple

An electronically controlled start-up function, coupled with the ability to switch over manually from idle to full load operation, ensures a reliable start when operating in cold ambient conditions. Furthermore, the monitoring system can automatically shut down the compressor if needed.

Durable

The MOBILAIR M 82 is well equipped to face the gruelling continuous operation in harsh conditions required on many construction sites. Even standard versions are capable of operating in ambient temperatures ranging from -10° C to +45° C. The optional low-temperature version features engine coolant preheating, whilst synthetic cooling fluid is used in the airend.

Made in Germany

MOBILAIR portable compressors are manufactured at KAESER's headquarters in Coburg, Northern Bavaria. Equipped with the very latest technology, the recently modernised portable compressor plant boasts state-of-the-art equipment, including a TÜV-certified sound testing area for free-field sound level measurement, a complete powder-coating facility and efficient manufacturing logistics.



M 82: Generator option

The optional synchronous three-phase generator (IP 54) is available with a power of 8.5 or 13 kVa. These brushless, maintenance-free generators can be switched over from continuous operation to energy-saving automatic start, depending on current power requirements. The generator control panel can be equipped with a lockable cover flap if required.

Convenient layout with room to spare





Pure power and performance

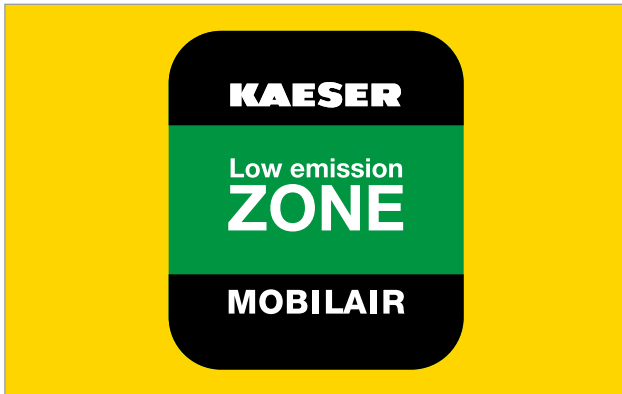

Low emissions

The M82 is certified in accordance with EU Directive 2016/1628, Stage V, to ensure clean-air operation wherever it is used – not just in Low Emission Zones. Furthermore, with a diesel particulate filter fitted as standard, the MOBILAIR 82 meets the stringent requirements of the Swiss Clean Air Act.



SIGMA CONTROL SMART

This advanced compressor controller ensures optimised compressed air availability, fuel efficiency and exhaust gas management using state-of-the-art electronic engine management. Functions include an operating mode display, intuitive user interface plus monitoring and system diagnostics.



SIGMA PROFILE airend

At the heart of every M 82 system lies a premium-quality airend featuring KAESER's energy-saving SIGMA PROFILE rotors. The airend's optimised flow characteristics enable it to deliver more compressed air for less energy.



Service-friendly and easy to access

All maintenance points are easily accessible via the large gull-wing doors, which makes service work fast and efficient. Optional customised service contracts are also available.

Details that count



Patented Anti-Frost Control

Specially developed by KAESER for portable compressors, the patented Anti-Frost Control automatically adjusts operating temperature in relation to ambient. In combination with the optional tool lubricator, this feature prevents air tools from freezing up and significantly extends their service life.



Cool and condensate-free

The compressed air is cooled to 7 °C above ambient temperature. Installed at an angle, the compressed air after-cooler ensures frost-proof performance even at the coldest times of the year. The axial centrifugal separator reliably removes the condensate, which is then evaporated.



Oil-lubricating or oil-free?

Depending on the application, the MOBILAIR M 82 can be optionally equipped with a tool lubricator for lubricating compressed air tools, or with a microfilter combination for blasting work requiring technically oil-free compressed air.



Dry compressed air

The plate-type heat exchanger reheats the cooled compressed air using heat from the compressor cooling fluid. This prevents condensation from forming outside the unit when the compressed air cools.



Always the right choice



Heat exchanger bypass

Infinitely variable compressed air discharge temperatures are optionally available via a ball valve in the plate-type heat exchanger, which is particularly useful for blasting applications.



Suitable for use in refineries

The M 82 is available with a certified spark arrester for refinery applications. In addition, the engine shut-off valve automatically shuts down the unit upon intake of combustible gases so as to ensure maximum safety.



M 82 – Kubota engine

Ensuring clean air not just in Low Emission Zones, a diesel particulate filter is fitted downstream from the Kubota engine as standard. It is therefore certified in accordance with EU Directive 2016/1628, Stage V and US exhaust emissions standard EPA Tier 4 final.

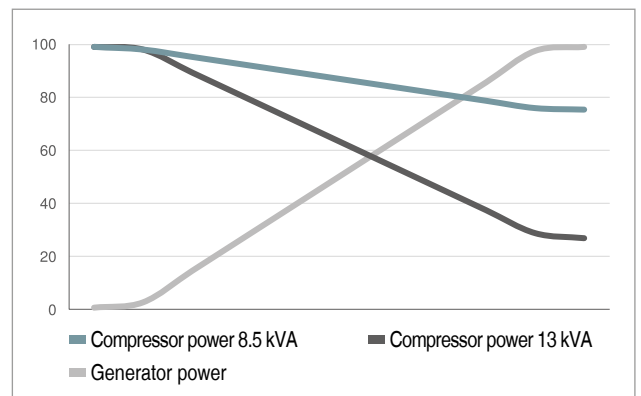

Perfect generator control

Ensuring perfect interplay with the engine management system, the M 82's advanced SIGMA CONTROL SMART compressor controller delivers maximum compressed air availability relative to power requirement.

Available equipment

Closed floor pan

The closed floor pan immediately catches any liquids, thereby preventing ground contamination in environmentally sensitive zones. All drainage holes are sealed with screw plugs.

Pressure variants

Models are available in a variety of pressure versions, ranging from 7 to 14 bar. Pressure can easily be reduced in increments of 0.5 bar down to 6 bar, using the SIGMA CONTROL SMART's simple arrow keys. Pressure adjustment can also be electronically disabled so as to prevent any unauthorised changes to the operating parameters.

Industrie 4.0 @ MOBILAIR

The MOBILAIR Fleet Management online tool provides operators with a wide range of data, including working pressure, fuel tank fill level, service alerts, precise physical location and duty cycle. To optimise service processes, the system sends notifications regarding, for example, fault causes and upcoming scheduled maintenance requirements.

Compressed air treatment variants

<p>System A</p> <ul style="list-style-type: none"> - Cool - Condensate-free 		<p>Cool, condensate-free compressed air (100 % saturated), for compressed air tools and temporary replacement of stationary compressors</p>
<p>System F</p> <ul style="list-style-type: none"> - Cool - Condensate-free - Filtered 		<p>Cool, condensate-free compressed air (100 % saturated), free from contaminant particles and technically oil-free in accordance with applicable regulations</p>
<p>System B</p> <ul style="list-style-type: none"> - Warmed - Dried 		<p>Dried compressed air, reheated to at least 20 °C, for working at sub-zero temperatures and with longer air lines</p>
<p>System G</p> <ul style="list-style-type: none"> - Warmed - Dried - Filtered 		<p>Dried compressed air, reheated to at least 20 °C, free from contaminant particles and technically oil-free in accordance with applicable regulations</p>
<p>Fresh air</p> <p>As partial flow</p>	<p>Does not provide protection against carbon monoxide (CO) or other noxious gases</p>	<p>Odour-free fresh air connected via a separate quick-release coupling</p> <p>(Only in combination with F or G systems)</p>

Technical specifications

Model	Compressor				4-cylinder diesel engine (water-cooled)				Complete system				
	Flow rate		Gauge working pressure		Make	Type	Rated engine power	Speed at full load	Fuel tank capacity	Operating weight	Sound power level	Sound pressure level	Compressed air outlet
	m ³ /min	cfm	bar	PSI									
M 82	8.4	295	7	100	Kubota	V 3307-CR-T	54.6	2400	140	1580	≤ 98	67	1 x G 1½, 3 x G ¾
	6.8	240	10	145									
	6.1	215	12	175									
	5.5	195	14	200									

¹⁾ Applies to standard unit incl. chassis with overrun brake, without air treatment

²⁾ Guaranteed sound power level as per 2000/14/EC

³⁾ Surface sound pressure level measured as per ISO 3744 (r: 10m)

Dimensions

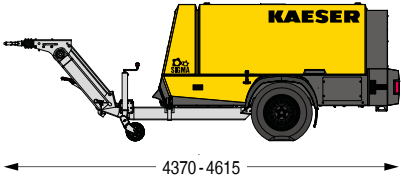
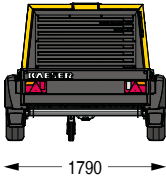
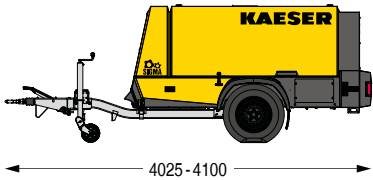
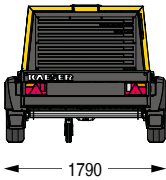
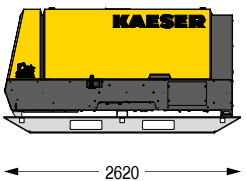
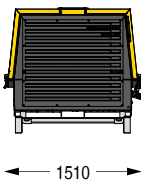
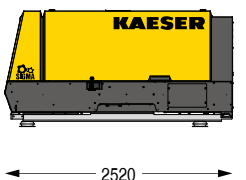
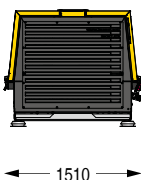
Height-adjustable version	 4370 - 4615	 1790 1525
Fixed version	 4025 - 4100	 1790 1525
Skid-mounted version	 2620	 1510 1385
Stationary version	 2520	 1510 1285 - 1345

The world is our home

As one of the world's largest compressed air system providers and compressor manufacturers, KAESER KOMPRESSOREN is represented throughout the world by a comprehensive network of branches, subsidiary companies and authorised partners in over 120 countries.

With innovative products and services, KAESER KOMPRESSOREN's experienced consultants and engineers help customers to enhance their competitive edge by working in close partnership to develop progressive system concepts that continuously push the boundaries of performance and compressed air efficiency.

Moreover, the decades of knowledge and expertise from this industry-leading system provider are made available to each and every customer via the KAESER group's global computer network.

These advantages, coupled with KAESER's worldwide service organisation, ensure that every product operates at the peak of its performance at all times and provides maximum availability.



KAESER KOMPRESSOREN SE

P.O. Box 2143 – 96410 Coburg – GERMANY – Tel +49 9561 640-0 – Fax +49 9561 640-130
e-mail: productinfo@kaeser.com – www.kaeser.com